

# EtherNet/IP In-cabinet System Specifications

Catalog Numbers: 1834-AENTR, 1834-SUP-PWR, 1486-CBL, 1486-CON, 100-E-INT-D, 100-E-INT-X, 104-E-INT-D, 104-E-INT-X, 800F-INT, 800F-INT-L

---

**Topic**

---

[1834-AENTR Gateway on page 3](#)

---

[1486-CBL Flat Media Cable on page 8](#)

---

[1486-CON Connectors on page 12](#)

---

[100-E and 104-E Contactor Communication Interface Modules on page 16](#)

---

[800F-INT Push Button Communication Interface Modules on page 21](#)

---

[1834-SUP-PWR Supplemental Power Tap on page 25](#)

---

[Additional Resources on page 27](#)

---

## Summary of Changes

This publication contains the following new or updated information. This list includes substantive updates only and is not intended to reflect all changes. Translated versions are not always available for each revision.

The following information is new or updated throughout:

- Added 1834-SUP-PWR supplemental power tap information
- Omitted content referencing the 100-E-INT communication interface module
- Included screen captures to referencing the configuration and monitoring of 100/104-E-INT-X communication interface modules

# 1834-AENTR Gateway

## 1834-AENTR Gateway

The 1834-AENTR gateway is the primary network power source. It connects the devices on the EtherNet/IP™ In-cabinet bus to a standard EtherNet/IP™ network to allow communication between a Logix 5000® controller and the devices.

Figure 1. 1834-AENTR Gateway



Features include:

- Dual RJ45 ports for Device Level Ring (DLR) connection, Dynamic Host Configuration Protocol (DHCP), or rotary switch to set the IP address
- One 1486-CBL flat media cable connection
- Auto-IP commissioning of connected devices
- Configuration using programming software
- Maximum of 40 node connections (includes the gateway as 1 connection)
- Maximum of 25 m (82 ft) flat media cable per gateway

## 1834-AENTR Gateway Specifications

For a complete list of standards compliance and certifications, visit our Product Certifications website, [rok.auto/certifications](http://rok.auto/certifications), and use '1834-CT' as your search term.

### Technical Specifications

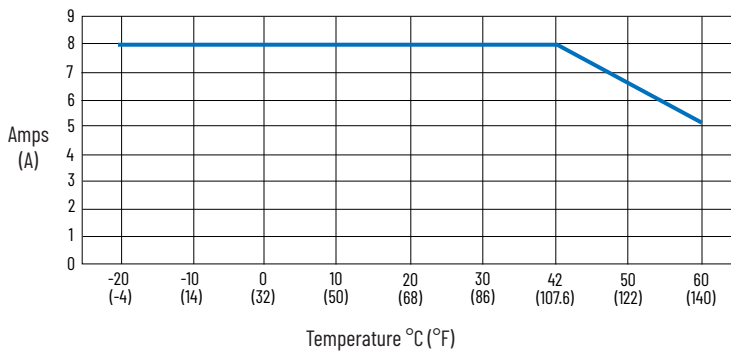
The current rating is dependent on the primary power supply size. NP and SP current is derated at above 40 °C (104 °F). NP and SP outputs must not be interconnected.

**Table 1. 1834-AENTR Gateway Electrical Specifications**

Attribute	Value	
Input power supply	Requirements/conformance	SELV/PELV, maximum 960 watts
	Terminal designations	24V DC, (+), (-), $\frac{\oplus}{\ominus}$ , accepts wire diameter of 12 AWG
	Voltage range	24V DC +/- 10%
	Current	0.1 A minimum, 8.2 A maximum
	Maximum DC power cable length	Distance between power supply and gateway: 3 m (9.80 ft)
Network power (NP)	Output voltage	21.1V DC minimum, 26.4V DC maximum
	Output current	4 A maximum continuous, 8 A maximum for no longer than 5 s
	Output power	100VA maximum
Switched power (SP)	Output voltage	21.1V DC minimum, 26.4V DC maximum
	Output current	4 A maximum continuous, 8 A maximum for no longer than 5 s
	Output power	100VA maximum
EtherNet/IP™ In-cabinet System MTBF	90,000 hours	

**Derating**

**Figure 2. Combined Current Rating for Gateway Output (Network Power and Switched Power)**



## EtherNet/IP In-cabinet System Environmental Specifications



**ATTENTION:**  
**Environment and Enclosure**

This equipment is intended for use in a Pollution Degree 2 industrial environment, in overvoltage Category II applications (as defined in EN/IEC 60664-1), at altitudes up to 2000 m (6562 ft) without derating. This equipment is not intended for use in residential environments and may not provide adequate protection to radio communication services in such environments. This equipment is designated and supplied as open-type equipment for indoor use. It must be mounted within an enclosure that is suitably designed for those specific environmental conditions that are present and appropriately designed to help prevent personal injury resulting from accessibility to live parts. The enclosure must have suitable flame-retardant properties to prevent or minimize the spread of flame, complying with a flame spread rating of 5VA or be approved for the application if nonmetallic. The interior of the enclosure must be accessible only by the use of a tool. Subsequent sections of this publication may contain more information regarding specific enclosure type ratings that are required to comply with certain product safety certifications. In addition to this publication, see the following:

- Industrial Automation Wiring and Grounding Guidelines, publication [1770-4.1](#), for more installation requirements.
- NEMA Standard 250 and EN/IEC 60529, as applicable, for explanations of the degrees of protection provided by enclosures.

**Table 2. EtherNet/IP In-cabinet System Ambient Operating Temperature Specifications**

Enclosure Type	Temperature °C (°F)		
	Minimum	No Derating	With Derating
Open (IP 20 / Open Type)	-20 °C (-4 °F)	42 °C (107.6 °F)	60 °C (140 °F)
Enclosed (Non-ventilated) <sup>1</sup>	-20 °C (-4 °F)	22 °C (71.6 °F)	40 °C (104 °F)

**Table 3. EtherNet/IP In-cabinet System Storage Temperature Specifications**

Temperature type	Temperature °C (°F)
Cold	-40 °C (-40 °F)
Dry heat	85 °C (185 °F)

**Table 4. EtherNet/IP In-cabinet System Immunity and Emission Specifications**

Attribute	Value
Radiated RF Immunity	10V/m, AM 80% (1 KHz), 80 MHz to 1 GHz
EIC 61000-4-3	3V/m, AM 80% (1 KHz), 1.4...6 GHz
EFT/B Immunity	+ /- 2 kV / 5 kHz, 100 kHz on power ports
IEC 61000-4-4	+/- 1 kV / 5 kHz, 100 kHz on signal ports
Conducted RF Immunity	10V rms with 1 KHz sine wave 80% AM from 150 kHz...80 MHz
IEC 61000-4-6	
Power Frequency Magnetic Immunity	30 A/m (50 Hz, 60 Hz)
IEC 61000-4-8	

1. This assumes that the air temperature difference between the inside and the outside of the enclosed enclosure is less than -20 °C (-4 °F).

**Table 4. EtherNet/IP In-cabinet System Immunity and Emission Specifications (continued)**

Attribute	Value
Surge Transient Immunity IEC 61000-4-5	+/- 2 KV line-earth on Ethernet ports
Conducted and Radiated Emission	CISPR 11 Class A Group 1

**Table 5. EtherNet/IP In-cabinet System Shock and Vibration Specifications**

Test	Criteria		Industry Standard
	Vibration (Unpackaged)	Shock (Unpackaged)	
Frequency Range	10...57 Hz	–	IEC 60068-2-6
Displacement	0.3 mm (0.01 in.) 57...500 Hz	–	
Acceleration	2 g	–	IEC 60068-2-27
	–	15 g (operational) 30 g (non-operational)	

**Accessories**

The flat media cable and connectors are IP20 rated. They are intended for in-cabinet installation only in UL 508 A Industrial Control Panels, UL 845 Motor Control Centers, and similar internal ordinary (non-hazardous) locations on an international basis.

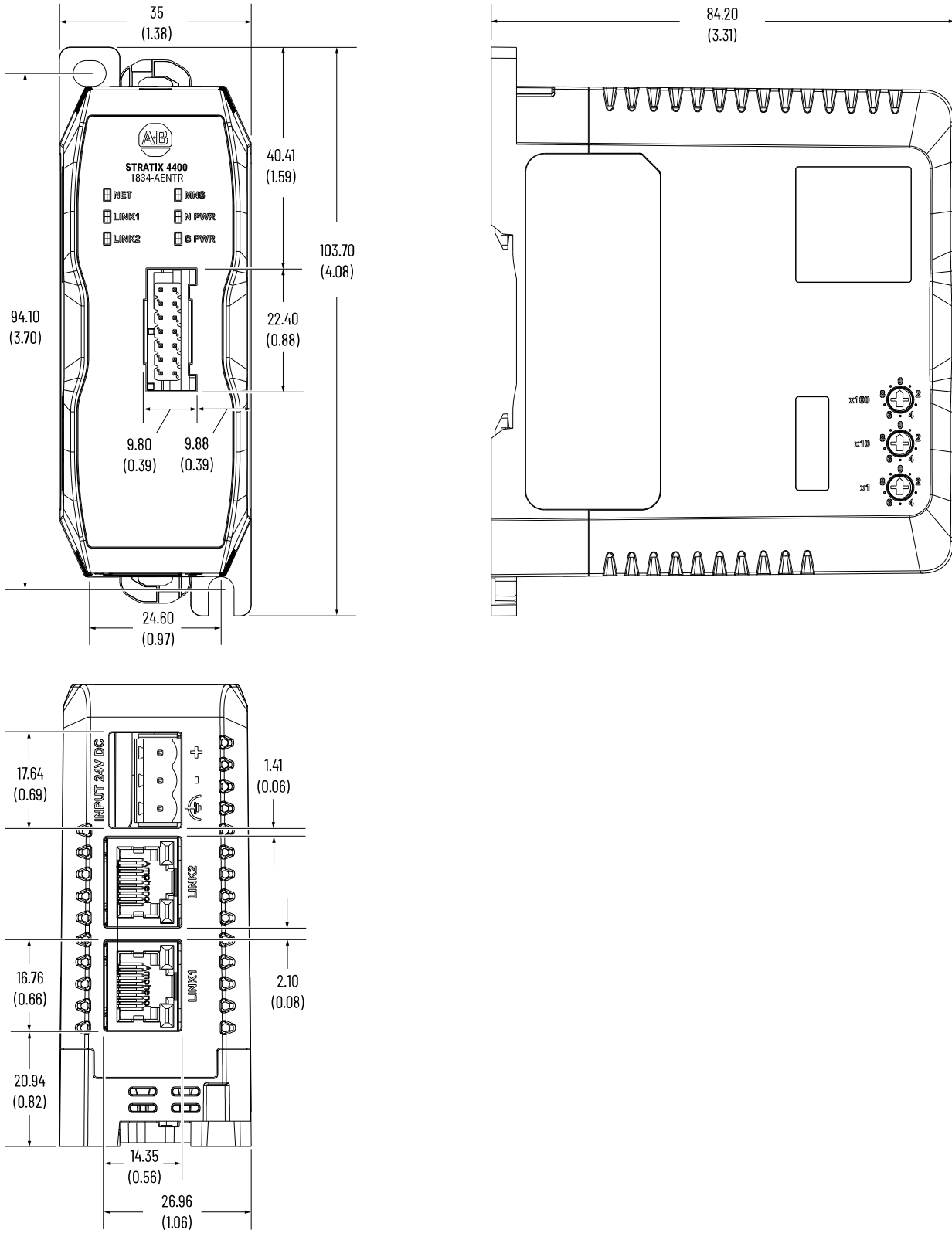
**Table 6. Accessories**

Product	Description	Cat. No.
Single pair Ethernet connection	Flat media cable connection to the end node device	1486-CON-P1
	Flat media cable extends to right (front facing for typical installation)	1486-CON-P2L
	Flat media cable extends to left (front facing)	1486-CON-P2R
Flat media cable 25 m (82 ft) maximum length	7-conductor flat cable, available in bulk spool	10 m (32 ft)
		25 m (82 ft)
		100 m (328 ft)
Flat media cable terminator	For each flat media network	1486-CON-T1

**1834-AENTR Gateway Approximate Dimensions**

Dimensions are shown in millimeters (inches). Dimensions are not intended to be used for manufacturing purposes.

Figure 3. 1834-AENTR Gateway Approximate Dimensions





# 1486-CBL Specifications

For a complete list of standards compliance and certifications, visit our Product Certifications website, [rok.auto/certifications](http://rok.auto/certifications), and use '1834-CT' as your search term.

## Considerations for Media Planning and Installation

**Table 8. Considerations for Media Planning and Installation**

Attribute	Value
Maximum cable length limit	Per 1834-AENTR gateway interface: 25 m (82 ft)
Rating limit	IP20 rated; for in-cabinet use only
Cable bend radius limit	Static installation: $\geq 5$ mm (0.22 in) Cable loops that move (such as at a door hinge): $\geq 30$ mm (1.18 in), 20x the cable thickness
Cable routing within control panel limit	Flat media cable cannot be bent along its length except for momentary slight bending during connector installation  <b>IMPORTANT:</b> Avoid routing near equipment that generates strong electric or strong magnetic fields. When routing, use proper cable supports such as Panduit® FCM1-A-C14

## Minimum Specifications and Requirements

Cable C1 is designed per ODVA Volume 2 EtherNet/IP Adaptation of Common Industrial Protocol (CIP), Section 8-10: Industrial EtherNet/IP In-cabinet Bus Media and Physical Layer.

**Table 9. Electrical**

Attribute	Value
Conductors	<ul style="list-style-type: none"> <li>SPE+, SPE-, SEL: 24 AWG, 7/32 stranded tin-coated copper</li> <li><math>0.23 \text{ mm}^2</math> strand <math>\varnothing</math> 0.203 mm / bundle <math>\varnothing</math> 0.61 mm</li> <li>Lay length of outer layer is from 12x...16x outer diameter (OD)</li> <li>NP+, NP-, SP+, SP-: 20 AWG, 19/32 stranded tin-coated copper</li> </ul>

**Table 9. Electrical (continued)**

Attribute	Value
	<ul style="list-style-type: none"> <li>0.61 mm<sup>2</sup> strand Ø 0.203 mm / bundle Ø 0.95 mm</li> <li>Lay length of all layers is from 12x...16x OD</li> </ul>
Impedance Ω	Reference impedance of 100 Ω for SPE pair
Insertion Loss IL (dB)	<ul style="list-style-type: none"> <li>Measured per section 8-10.4.4 for SPE pair at 25 m (82 ft) length</li> <li><math>0.25 * (2.73 * \sqrt{f}) + 0.026 * f + 0.375 / \sqrt{f}</math></li> <li><math>0.30 \leq f \leq 40</math> where f is the frequency in MHz</li> </ul>
Return Loss IL (dB)	<ul style="list-style-type: none"> <li>Measured per section 8-10.4.4 for SPE pair at 25 m (82 ft) length</li> <li><math>24 + 5 * \log_{10}(f/10)</math>, 24 maximum</li> <li><math>0.30 \leq f \leq 40</math> where f is the frequency in MHz</li> </ul>
Mode Conversion MC (dB)	<ul style="list-style-type: none"> <li>Measured per section 8-10.4.4 for SPE pair at 25 m (82 ft) length</li> <li>TCL and TCTL: <math>46 - 10 * \log_{10}(f)</math>, 40 max</li> <li><math>0.30 \leq f \leq 100</math> where f is the frequency in MHz</li> </ul>
Current	<ul style="list-style-type: none"> <li>NP+, NP-, SP+, SP-: 4 A minimum at 75 °C (167 °F) ambient</li> <li>SPE+, SPE-: 12 mA minimum at 75 °C (167 °F) ambient</li> </ul>
DCR	<ul style="list-style-type: none"> <li>Measured for each conductor at 25 m (82 ft) length at 20 °C (68 °F)</li> <li>NP and SP: 0.935 Ω maximum</li> <li>SPE and SEL: 2.355 Ω maximum</li> <li>(Reference: UL 1581)</li> </ul>
DCR Unbalance	<ul style="list-style-type: none"> <li>Measured per ASTM D456</li> <li>NP and SP: 3%</li> </ul>
Dielectric strength	2000V AC (Reference: UL 758, Table 29.1, 600V AC)

**Table 10. Mechanical**

Attribute	Value
Construction	<ul style="list-style-type: none"> <li>Parallel, multi-conductor cable with extruded integral insulation and no jacket or coverings</li> <li>For unrestricted internal use</li> <li>600V AC</li> <li>Tested for crush resistance per UL 758, Table 28.1</li> <li>Not required to be wet-rated or have oil, gas, or sunlight resistance</li> </ul>
Durometer	97 Shore A maximum or equivalent
Pulling tension	111 N, no damage precluding use, and all electrical parameters met



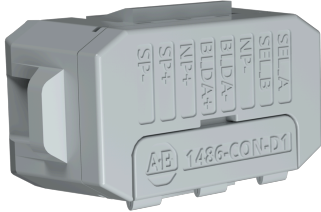

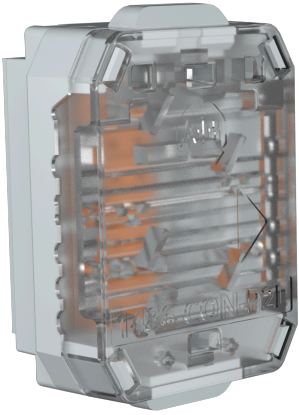
# 1486-CON Connectors

The bus uses 1486-CON connectors to attach system components to the 1486-CBL flat media cable.


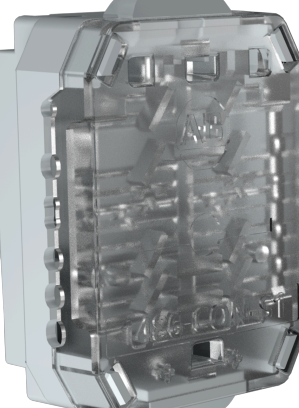

- 1486-CON connectors cannot be added to or removed from an active system.
- Any unpopulated connector must be capped with a 1486-CON-D1 connector cover.
- Only one device can be removed at a time.

The following table shows available 1486-CON connectors for your EtherNet/IP™ In-cabinet system.

**Table 12. 1486-CON Connectors**

Cat No.	Description	For Use with	Connector Supplied with Cat. No.
<p>1486-CON-D1</p> 	<p>Connector cover with test access points</p>	<p>1486-CON-P1 connectors installed on the cable, which are unused or unplugged</p>	<p>—</p>
<p>1486-CON-P1</p> 	<p>Connector, straight through</p>	<p>100-E, 104-E, 800F communication interfaces</p>	<p>100-E-INT-D, 100E-INT-X, 104-E-INT-D, 104-E-INT-X, 800F-INT, 800F-INT-L</p>
<p>1486-CON-P2L</p> 	<p>Connector, covers left end of cable</p>	<p>1834-AENTR gateway and 1834-SUP-PWR supplemental power tap</p>	<p>1834-AENTR, 1834-SUP-PWR</p>

**Table 12. 1486-CON Connectors (continued)**

Cat No.	Description	For Use with	Connector Supplied with Cat. No.
<p>1486-CON-P2R</p> 	<p>Connector, covers right end of cable</p>	<p>1834-AENTR gateway and 1834-SUP-PWR supplemental power tap</p>	<p>1834-SUP-PWR</p>
<p>1486-CON-S1</p> 	<p>Connector, joins two cables</p>	<p>Extending or repairing cable</p>	<p>—</p>
<p>1486-CON-T1</p> 	<p>Connector, media termination</p>	<p>End of bus/cable</p>	<p>1834-AENTR</p>

## 1486-CON Connectors Specifications

For a complete list of standards compliance and certifications, visit our Product Certifications website, [rok.auto/certifications](http://rok.auto/certifications), and use '1834-CT' as your search term.

## Technical Specifications

**Table 13. 1486-CON Electrical Specifications**

Attribute	Value
Working voltage	30V DC maximum
Operating current	1486-CON-P1: 2 A maximum
	1486-CON-P2L, 1486-CON-P2R, and 1486-CON-S1: 4 A maximum
Connected devices, maximum	40

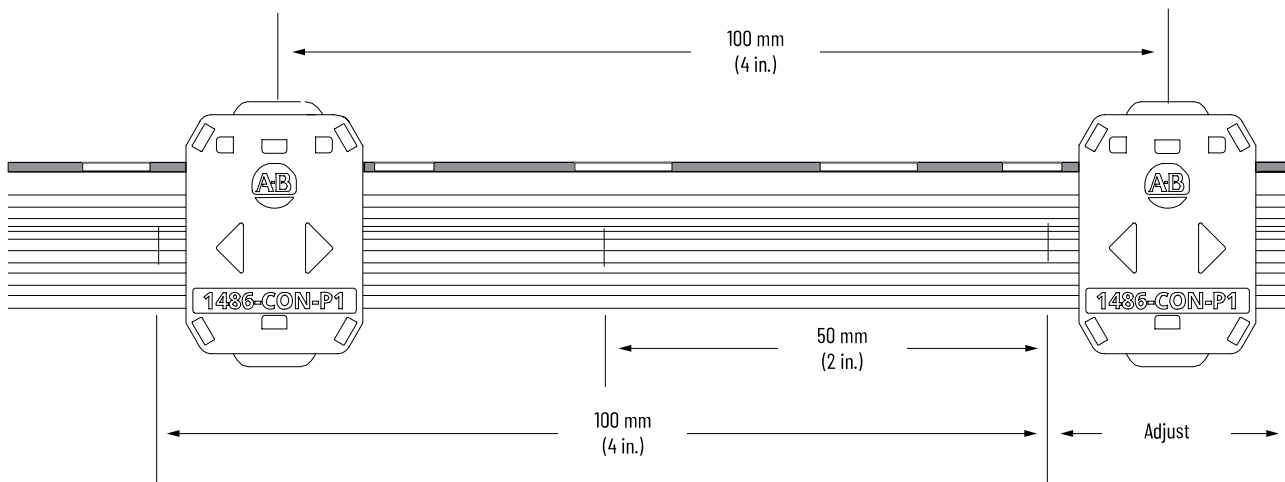
### Spacing Requirements

The 1486-CBL flat media cable and 1486-CON connector must be spaced as follows:

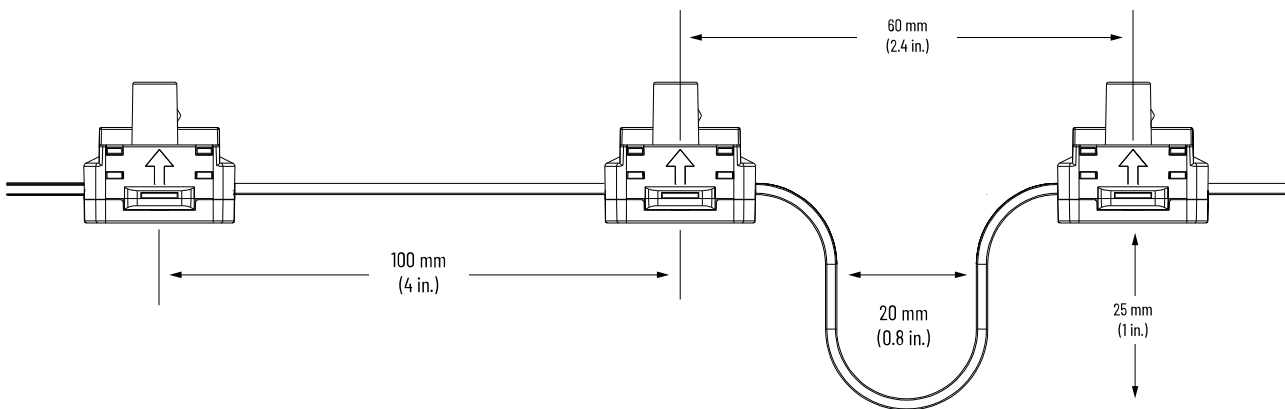
- Provide 100 mm (4 in.) of initial spacing to allow for cable slack to ease connector insertion/reinsertion.
- Adjust the spacing based on the adjacent supported device dimensions to achieve desired cable slack.

The minimum spacing is 50 mm (2 in.).

**Figure 7. Spacing Requirements**

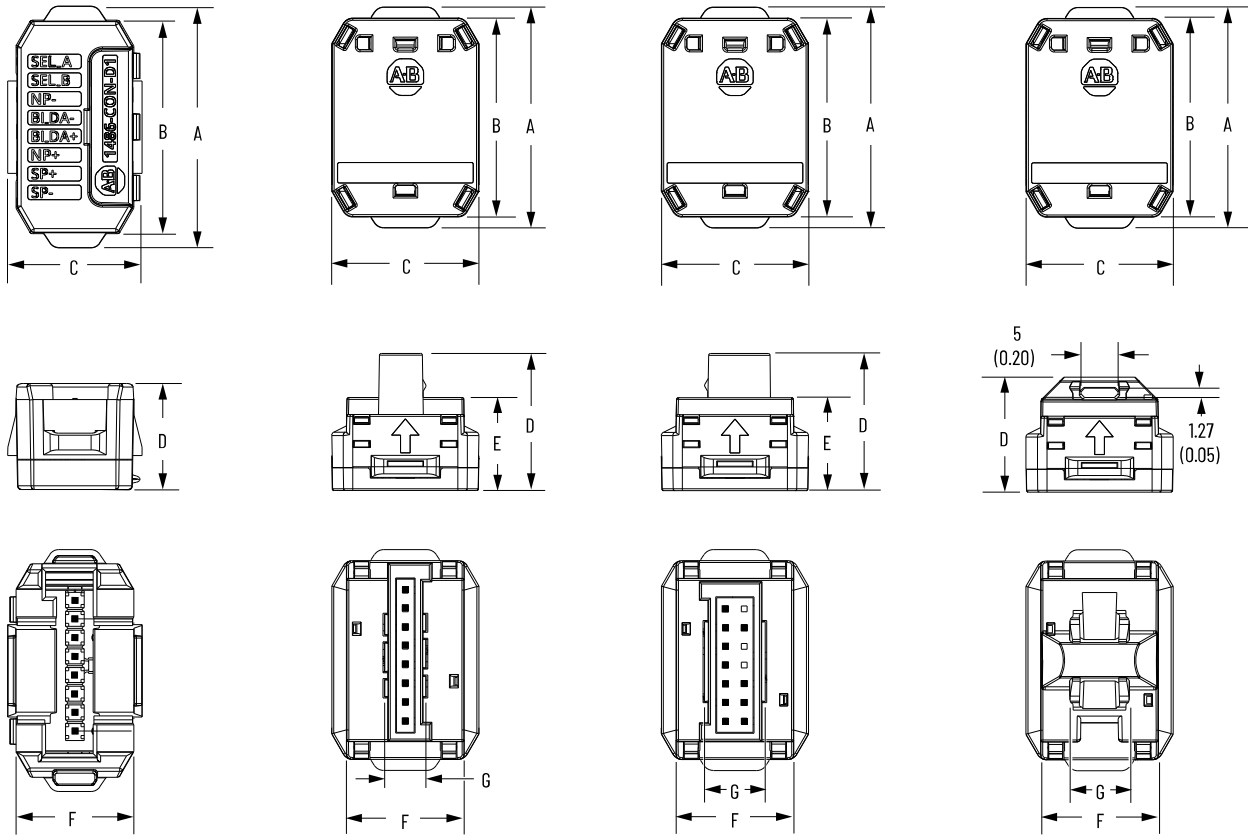


**Figure 8. Example: 1486-CBL Flat Media Cable Slack Using 100 mm (4 in.) Spacing**



# 1486-CON Connectors Approximate Dimensions

Dimensions are shown in millimeters (inches). Dimensions are not intended to be used for manufacturing purposes.



**Table 14. 1486-CON Dimensions**

Cat. No.	Dimension mm (in.)						
	A	B	C	D	E	F	G
1486-CON-D1	32.8 (1.29)	29 (1.14)	18.3 (0.72)	14.5 (0.57)	—	16 (0.63)	—
1486-CON-P1	30 (1.18)	27 (1.06)	20 (0.79)	18.6 (0.73)	12.6 (0.50)	16 (0.63)	5.60 (0.22)
1486-CON-P2L	30 (1.18)	27 (1.06)	20 (0.79)	18.6 (0.73)	12.6 (0.50)	16 (0.63)	8.25 (0.32)
1486-CON-P2R							8.05 (0.32)
1486-CON-S1	30 (1.18)	27 (1.06)	20 (0.79)	14.5 (0.57)	12.6 (0.50)	16 (0.63)	8.05 (0.32)
1486-CON-T1							8.05 (0.32)

# 100-E and 104-E Contactor Communication Interface Modules

100-E and 104-E communication interface modules connect the starters to the system.

## 100-E and 104-E Communication Interface Modules Specifications

For a complete list of standards compliance and certifications, visit our Product Certifications website, [rok.auto/certifications](http://rok.auto/certifications), and use '1834-CT' as your search term.

### Technical Specifications

Power is provided to the devices via the 1486 flat media cable.

The data port on a 100/104-E-INT-X module enables data and communications to and from 140 ME Electronic Circuit Breakers or E100 (193-1EF) Advanced Overload Relays.

**Table 15. 100-E and 104-E Communication Interface Module Technical Specifications**

Attribute		Value
Network power (NP)	Input voltage	11V DC minimum, 26.4V DC maximum
	Input current	30 mA maximum, continuous
Switched power (SP)	Input voltage	26.4V DC maximum
	Input current	Variable based on 100-E contactor coil types
Auxiliary (aux) input		Current and voltage that is provided by 100-E/104-E via push-in 14...28 AWG to dry contact aux input as defined in IEC60947-1 standard
Data port connection		Via component serial interface cable 100-E-X-CBL

### Input Current Specifications, Pick-up/Hold-in, for 100-E/104-E Coils

**Table 16. 100-E and 104-E Communication Interface Module Input Current Specifications**

Attribute		Value	
Energy-efficient [EJ]	24...60V AC, 20...60V DC	100-E(09...38)EJ / 104-E(09...38)EJ	12...16 / 1.7 [W]
Standard AC/DC	24...60V AC, 20...60V DC	100-E(40...65)KJ / 104-E(40...65)KJ	25 / 2 [W]
		100-E(80...96)KJ / 104-E(80...96)KJ	40 / 2 [W]
Low Consumption/Faster Drop-out DC	24V DC	100-E(09...38)QJ / 104-E(09...38)QJ	6 / 1.7 [W]

# Mounting Interface with Bulletin 100-E Contactors

**Table 17. Mounting Interface with Bulletin 100-E Contactors**

Size	EJ Low Consumption	QJ Low Consumption, Faster Drop-out	KJ Standard
1	100-E09EJ	100-E09QJ	—
	100-E12EJ	100-E12QJ	
	100-E16EJ	100-E16QJ	
2	100-E26EJ	100-E26QJ	—
	100-E30EJ	100-E30QJ	
	100-E38EJ	100-E38QJ	
3	—	—	100-E40KJ
			100-E52KJ
			100-E65KJ
3.5	—	—	100-E80KJ
			100-E96KJ

## Starter Modes Depending on the Controlled-by Option

### 100-E and 104-E Starter Modes

The 100-E and 104-E starters operate as follows, depending on the 'Controlled By' option.

**Table 18. Starter Modes Depending on the Controlled-By Option**

Controlled By	Peer Command	100-E-INT-D	104-E-INT-D	100-E-INT-X	104-E-INT-X
Controller	None	✓	✓	✓	✓
Controller/peer 2-wire	Run Forward	—	✓	—	✓
	Run Reverse	—	✓	—	✓
	Stop	—	—	—	—
	Hand	✓	✓	✓	✓
	Off	✓	✓	✓	✓
	Auto	✓	✓	✓	✓
	Reset	—	—	—	✓

**Table 18. Starter Modes Depending on the Controlled-By Option (continued)**

Controlled By	Peer Command	100-E-INT-D	104-E-INT-D	100-E-INT-X	104-E-INT-X
Controller/peer 3-wire	Run Forward	✓	✓	✓	✓
	Run Reverse	–	✓	–	✓
	Stop	✓	✓	✓	✓
	Hand	✓	✓	✓	✓
	Off	✓	✓	✓	✓
	Auto	✓	✓	✓	✓
	Reset	–	–	✓	✓
Peer 2-wire	Run Forward	✓	✓	✓	✓
	Run Reverse	–	✓	–	✓
	Reset	–	–	✓	✓
Peer 3-wire	Run Forward	✓	✓	✓	✓
	Run Reverse	–	✓	–	✓
	Stop	✓	✓	✓	✓
	Reset	–	–	✓	✓

## 100-E and 104-E Communication Interface Modules Approximate Dimensions

Dimensions are shown in millimeters (inches). Dimensions are not intended to be used for manufacturing purposes.

Figure 9. 100-E Module Approximate Dimensions (100-E-INT-X shown)

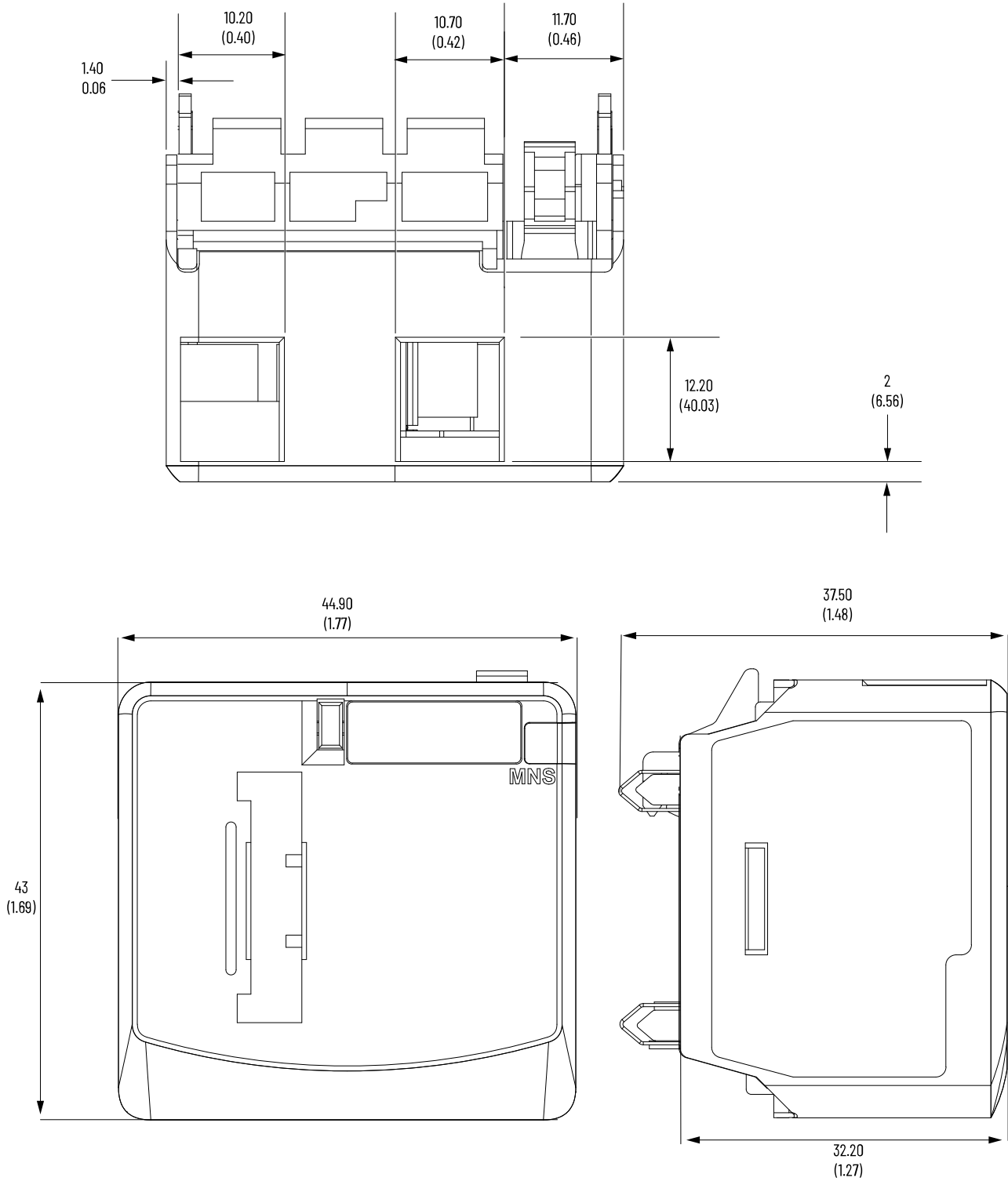


Figure 10. 104-E Module Approximate Dimensions (104-E-INT-D shown)

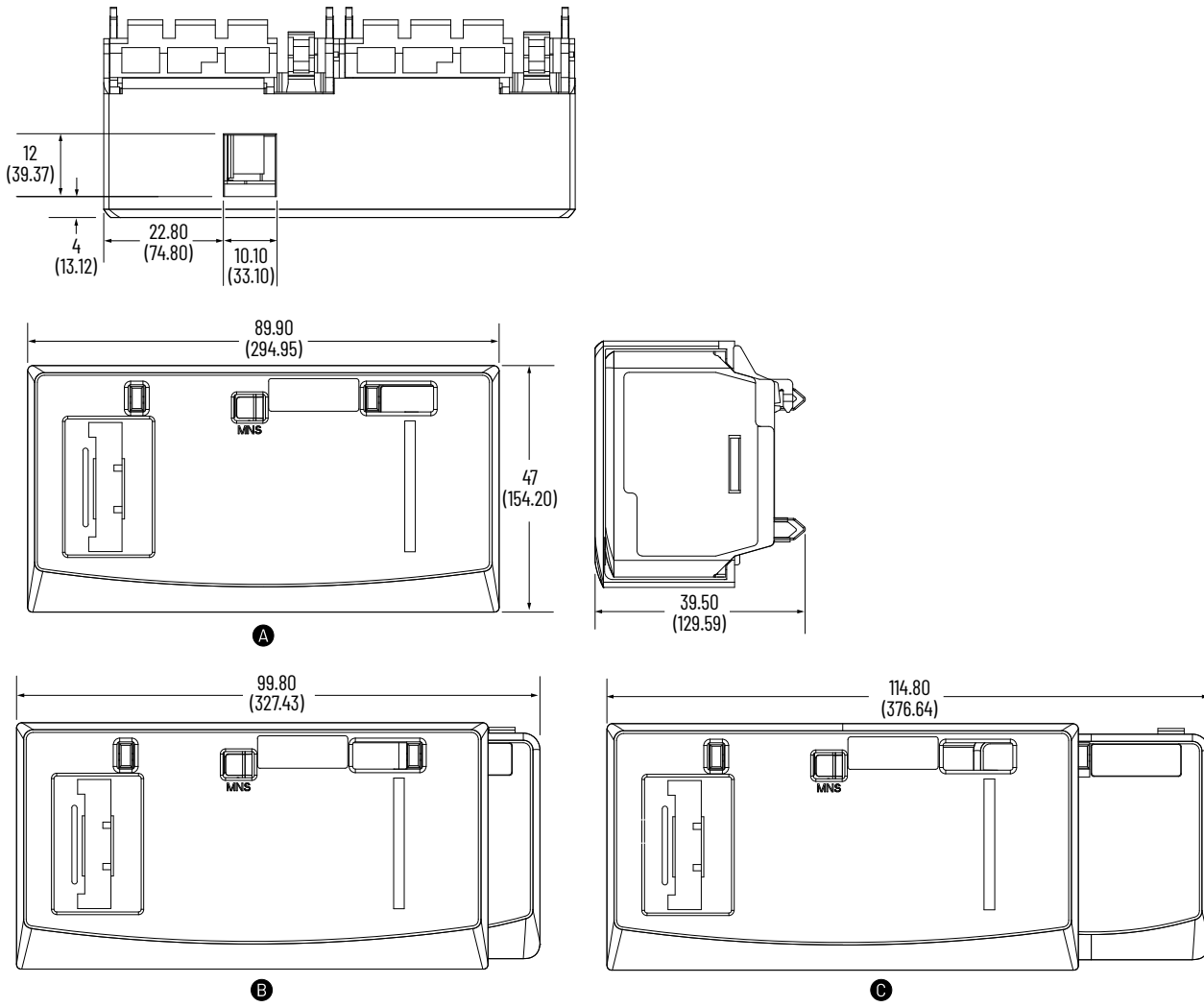


Table 19. 104-E Communication Interface Module Dimensions

Item	Description
A	Size 1 and 2
B	Size 3
C	Size 3.5

# 800F-INT Push Button Communication Interface Modules

800F communication interface modules connect the push buttons to the system and enhance 800F In-cabinet input devices for electrical control and switching. 800F communication interface modules are available as non-illuminated or illuminated and can be snap-fit to 800F-ALP and 800F-ALM latches.

## Supported 800F Operators

For product selection and technical data for the supported 800F operators that are listed, see 22 mm Push Button Specifications Technical Data, publication [800-TD008](#).

For global governing standards, see the Emergency Stop Push Buttons white paper, publication [800-WP008](#).

Use of a colorless, clear lens (option 7) of 800F illuminated operators is recommended.

**Table 20. Supported 800F Operators**

800F Operator	Type		Cat. No.	
			For 800F-INT	For 800F-INT-L
Push button	Momentary	Flush	800F_-F_	800F_-LF_
		Extended	800F_-E_	800F_-LE_
		Guarded	800F_-G_	800F_-LG_
		Mushroom	800F_-MM_	800F_-LMM_
	Trigger action	Push, twist-to-release	800F_-MT_	800F_-LMT_
		Push-pull	800F_-MP_	800F_-LMP_
Key release		800F_-MK4_	—	
Selector switches, 2-position	Standard knob		800F_-SM2_	800F_-LSM2_
			800F_-SR2_	800F_-LSR2_
	Knob lever		800F_-HM2_	800F_-LHM2_
			800F_-HR2_	800F_-LHR2_
	Key operator		800F_-KM2_	—
			800F_-KR2_	—
Selector switches, 3-position	Standard knob		800F_-SM3_	800F_-LSM3_
			800F_-SL3_	800F_-LSL3_
			800F_-SR3_	800F_-LSR3_
	Knob lever		800F_-HM3_	800F_-LHM3_

**Table 20. Supported 800F Operators (continued)**

800F Operator	Type	Cat. No.	
		For 800F-INT	For 800F-INT-L
		800F_-HL3_	800F_-LHL3_
		800F_-HR3_	800F_-LHR3_
	Key operator	800F_-KM3_	—
		800F_-KL3_	—
		800F_-KR3_	—
Momentary multi-operator	2-function	800F_-U2	800F_-LU2

## 800F-INT Communication Interface Modules Specifications

For a complete list of standards compliance and certifications, visit our Product Certifications website, [rok.auto/certifications](http://rok.auto/certifications), and use '1834-CT' as your search term.

### Technical Specifications

Power is provided from the 1486-CBL flat media cable.

**Table 21. 800F-INT Communication Interface Modules Network Power Specifications**

Attribute		Value
Network power	Input voltage	11V DC minimum, 26.4V DC maximum
	Input current	30 mA maximum, continuous

## Illuminated 800F Push Button Modes Controlled by Controller or Peer Device

### Illuminated 800F Push Button Modes

The illuminated 800F push buttons have these display modes.

**Table 22. Illuminated 800F Push Button Modes**

Mode	Colors
Light color	<ul style="list-style-type: none"> <li>• Red</li> <li>• Green</li> <li>• White</li> <li>• Blue</li> <li>• Yellow</li> <li>• Turquoise</li> </ul>

**Table 22. Illuminated 800F Push Button Modes (continued)**

Mode	Colors
	<ul style="list-style-type: none"> <li>• Magenta</li> <li>• Amber</li> </ul>
Light state	<ul style="list-style-type: none"> <li>• Illumination off</li> <li>• Illumination on</li> <li>• Blink</li> <li>• Dim</li> <li>• Blink and dim</li> </ul>
Trigger condition	<ul style="list-style-type: none"> <li>• All selected states are true</li> <li>• One or more of the source states are true (default)</li> <li>• None of the selected source states are true</li> </ul>

## 800F-INT Communication Interface Modules Approximate Dimensions

Dimensions are shown in millimeters (inches). Dimensions are not intended to be used for manufacturing purposes.

**Figure 11. 800F-INT Communication Interface Module**

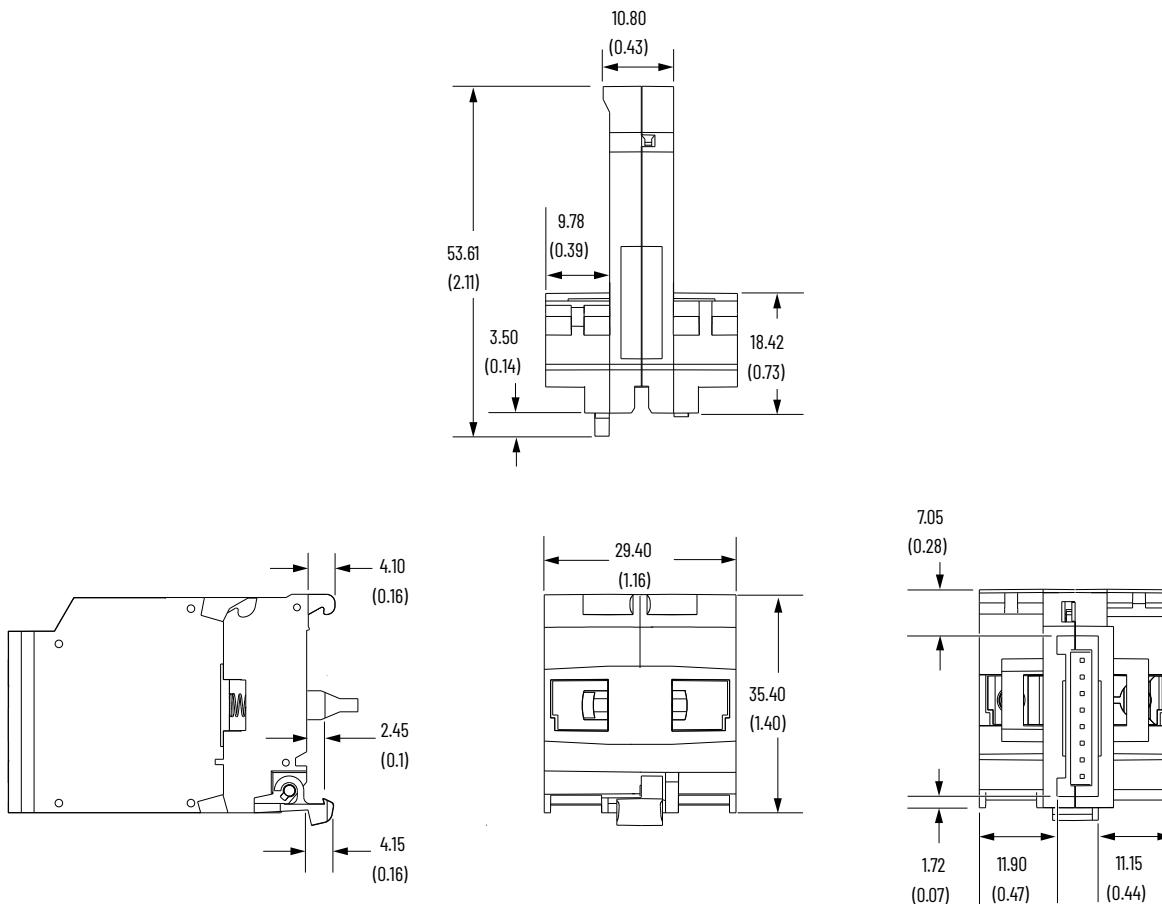
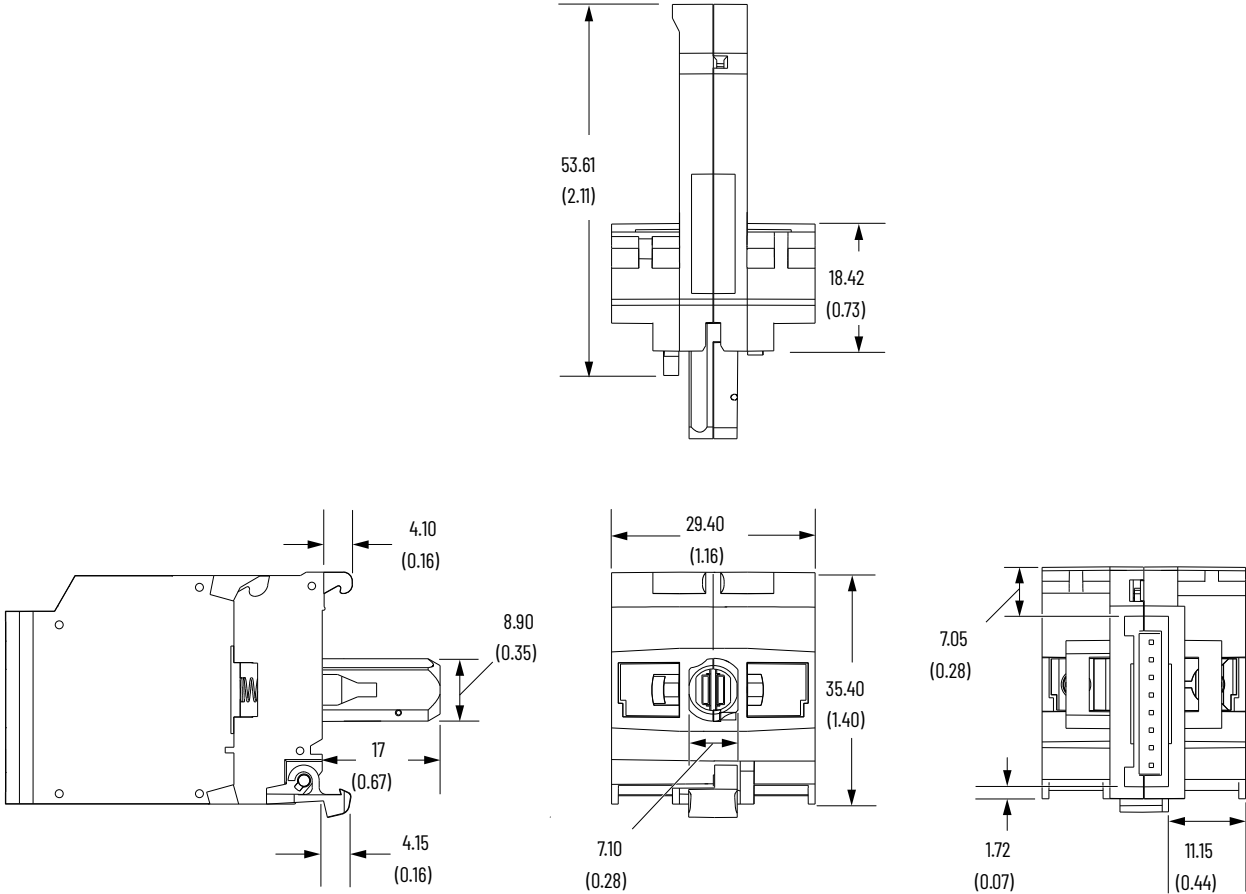


Figure 12. 800F-INT-L Communication Interface Module



# 1834-SUP-PWR Supplemental Power Tap

The 1834-SUP-PWR supplemental power tap uses external power to inject and regulate added switched power to the bus. The supplemental power tap is essential if the switched power provided by the integrated gateway becomes insufficient due to an increased number of devices.

## 1834-SUP-PWR Supplemental Power Tap Specifications

For a complete list of standards compliance and certifications, visit our Product Certifications website, [rok.auto/certifications](http://rok.auto/certifications), and use '1834-CT' as your search term.

### Technical Specifications

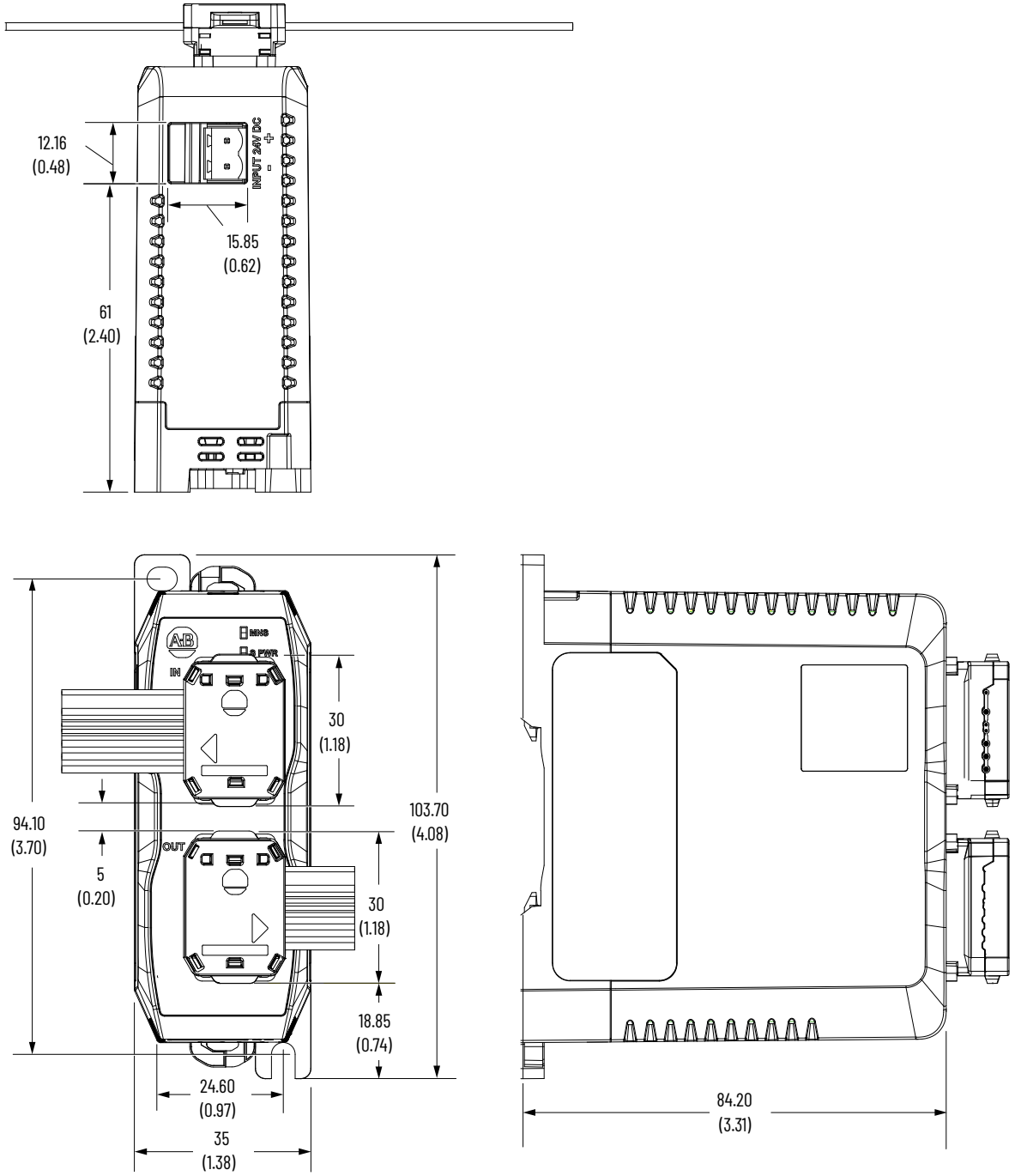
**Table 23. 1834-SUP-PWR Electrical Specifications**

Attribute		Value
Input power supply	Requirements/conformance	SELV/PELV UL/CSA/IEC/EN 61010-2-201
	Terminal designations	24V DC, (+), (-), accepts wire diameter of 12 AWG
	Voltage range	24V DC +/- 10%
	Current	0.05 A minimum, 4.1 A maximum
	DC power cable length	Max distance between power supply and the power tap: 3 m (9.80 ft)
Output	Switched power (SP)	100VA maximum
	SP output voltage	21.1V DC min, 26.4V DC maximum
	SP output current	4 A maximum continuous, 8 A maximum for no longer than 5 s
	Network power (NP)	NP (+), NP (-) are passed through from the gateway interface

## 1834-SUP-PWR Supplemental Power Tap Approximate Dimensions

Dimensions are shown in millimeters (inches). Dimensions are not intended to be used for manufacturing purposes.

Figure 13. 1834-SUP-PWR Supplemental Power Tap Approximate Dimensions



# Additional Resources

These documents contain additional information concerning related products from Rockwell Automation. You can view or download publications at [rok.auto/literature](http://rok.auto/literature).

**Table 24. Additional Resources**

Resource	Description
EtherNet/IP In-cabinet System <a href="#">technical documentation</a>	Quickly access and download technical specifications, installation instructions, and user manuals.
EtherNet/IP In-cabinet System: Gateway Product Information, publication <a href="#">1834-PC001</a>	Provides product information for the 1834-AENTR Gateway
EtherNet/IP In-cabinet System: Supplemental Power Tap Product Information, publication <a href="#">1834-PC002</a>	Provides product information for the 1834-SUP-PWR supplemental power tap
EtherNet/IP In-cabinet System: Contactor Communication Interface Modules for 100-E and 104-E Contactors Product Information, publication <a href="#">1834-PC003</a>	Provides product information for the EtherNet/IP™ In-cabinet System contactor communication interface modules for 100-E and 104-E contactors, Cat. No. 100-E-INT-D, 100-E-INT-X, 104-E-INT-D, and 104-E-INT-X.
EtherNet/IP In-cabinet System: Push Button Communication Interface Modules for 800F Operators Product Information, publication <a href="#">1834-PC004</a>	Provides product information for the push button communication interface modules for Bulletin 800F operators, Cat. No. 800F-INT and 800F-INT-L.
EtherNet/IP In-cabinet System User Manual, publication <a href="#">1834-UM001</a>	Provides guidance to plan, configure, diagnose, and troubleshoot the EtherNet/IP™ In-cabinet System.
22 mm Push Button Specifications Technical Data, publication <a href="#">800-TD008</a>	Provides product selection and technical data for Bulletin 800F operators and related accessories.
EtherNet/IP Network Devices User Manual, publication <a href="#">ENET-UM006</a>	Describes how to configure and use EtherNet/IP™ devices to communicate on the network.
Ethernet Reference Manual, publication <a href="#">ENET-RM002</a>	Describes basic Ethernet concepts, infrastructure components, and infrastructure features.
Common Industrial Protocol™ (CIP) Security with Rockwell Automation Products, publication <a href="#">SECURE-AT001</a>	Describes how to implement the CIP Security standard in your industrial automation control system (IACS).
FactoryTalk Security Application Technique, publication <a href="#">SECURE-AT002</a>	Describes how to use FactoryTalk® Security to implement authentication and authorization in your industrial automation system and enforce product-specific security for Studio 5000 Logix Designer®, FactoryTalk View, and FactoryTalk AssetCentre.
System Security Design Guidelines Reference Manual, publication <a href="#">SECURE-RM001</a>	Provides guidance on how to conduct security assessments, implement Rockwell Automation products in a secure system, harden the control system, manage user access, and dispose of equipment.
UL Standards Listing for Industrial Control Products, publication <a href="#">CMPNTS-SR002</a>	Assists original equipment manufacturers (OEMs) with the construction of panels, to help achieve that they conform to the requirements of Underwriters Laboratories.
Safety Guidelines for the Application, Installation, and Maintenance of Solid-state Control, publication <a href="#">SGI-1.1</a>	Designed to harmonize with NEMA Standards Publication No. ICS 1.1-1987 and provides general guidelines for the application, installation, and maintenance of solid-state control in the form of individual devices or packaged assemblies incorporating solid-state components.

**Table 24. Additional Resources (continued)**

Resource	Description
Industrial Automation Wiring and Grounding Guidelines, publication <a href="#">1770-4.1</a>	Provides general guidelines for installing a Rockwell Automation industrial system.
Product Selection and Configuration tools website, <a href="http://rok.auto/systemtools">rok.auto/systemtools</a>	Helps configure complete, valid catalog numbers and build complete quotes based on detailed product information.
Product Certifications website, <a href="http://rok.auto/certifications">rok.auto/certifications</a>	Provides declarations of conformity, certificates, and other certification details.

# Rockwell Automation Support

Use these resources to access support information.

Technical Support Center	Find help with how-to videos, FAQs, chat, user forums, and product notification updates.	<a href="http://rok.auto/support">rok.auto/support</a>
Local Technical Support Phone Numbers	Locate the telephone number for your country.	<a href="http://rok.auto/phonesupport">rok.auto/phonesupport</a>
Technical Documentation Center	Quickly access and download technical specifications, installation instructions, and user manuals.	<a href="http://rok.auto/techdocs">rok.auto/techdocs</a>
Literature Library	Find installation instructions, manuals, brochures, and technical data publications.	<a href="http://rok.auto/literature">rok.auto/literature</a>
Product Compatibility and Download Center (PCDC)	Get help determining how products interact, check features and capabilities, and find associated firmware.	<a href="http://rok.auto/pcdc">rok.auto/pcdc</a>

## Documentation Feedback

Your comments help us serve your documentation needs better. If you have any suggestions on how to improve our content, complete the form at [rok.auto/docfeedback](http://rok.auto/docfeedback).

## Waste Electrical and Electronic Equipment (WEEE)



At the end of life, this equipment should be collected separately from any unsorted municipal waste.


Rockwell Automation maintains current product environmental information on its website at [rok.auto/pec](http://rok.auto/pec).

Allen-Bradley, Armor, ArmorBlock, ArmorBlock MaXum, ArmorPOINT, CompactBlock, Compact I/O, CompactLogix, ControlLogix, ControlLogix-XT, Data Highway Plus, DH+, DriveLogix, expanding human possibility, FLEX, FLEX Ex, FlexLogix, Guard I/O, GuardLogix, GuardLogix-XT, InView, MicroLogix, On-Machine, PanelView, PLC-2, PLC-3, PLC-5, POINT I/O, POINT Guard I/O, PowerFlex, Rockwell Automation, RSLogix 5000, SCANport, SLC, and SoftLogix are trademarks of Rockwell Automation, Inc.

CIP, CIP Security, ControlNet, DeviceNet, and EtherNet/IP are trademarks of ODVA, Inc.

Trademarks not belonging to Rockwell Automation are property of their respective companies

Rockwell Otomasyon Ticaret A.Ş. Kar Plaza İş Merkezi E Blok Kat:6 34752 İçerenköy, İstanbul, Tel: +90 (216) 5698400 EEE Yönetmeliğine Uygundur

Connect with us.    

**rockwellautomation.com** — expanding **human possibility**<sup>®</sup>

AMERICAS: Rockwell Automation, 1201 South Second Street, Milwaukee, WI 53204-2496 USA, Tel: (1) 414.382.2000

EUROPE/MIDDLE EAST/AFRICA: Rockwell Automation NV, Pegasus Park, De Kleetlaan 12a, 1831 Diegem, Belgium, Tel: (32) 2663 0600

ASIA PACIFIC: Rockwell Automation SEA Pte Ltd, 2 Corporation Road, #04-05, Main Lobby, Corporation Place, Singapore 618494, Tel: (65) 6510 6608

UNITED KINGDOM: Rockwell Automation Ltd., Pitfield, Kiln Farm, Milton Keynes, MK11 3DR, United Kingdom, Tel: (44)(1908) 838-800